

**Part Number: PT932-35160 (D-Cab)
PT932-35161 (C-Cab)**

Kit Contents

Item #	Quantity Req'd.	Description
1	1	Step Bar – Driver Side
2	1	Step Bar – Passenger Side
3	2	Front mounting bracket
4	4	Middle/Rear mounting bracket

Hardware Bag Contents

Item #	Quantity Req'd.	Description
1	24	M8 x 25mm Hex head bolt
2	24	M8 Flat washer
3	24	M8 Lock washer

Additional Items Required For Installation

Item #	Quantity Req'd.	Description
1		
2		
3		

Conflicts

Regular/Access Cab Models

Recommended Tools

Personal & Vehicle Protection	Notes
Safety glasses	
Safety gloves	(Optional)
Special Tools	Notes
None	
Installation Tools	Notes
Ratchet	
Socket	13mm
Extension	
Torque Wrench	0-50 N-m (0-37 ft-lbf)
Panel Pry Tool	Toyota SST 00002-06001-01
Special Chemicals	Notes
None	

General Applicability

D-Cab & C-Cab Models

Recommended Sequence of Application







Item #	Accessory
1	
2	

*Mandatory

Vehicle Service Parts (may be required for reassembly)

Item #	Quantity Req'd.	Description
1		
2		
3		

Legend

	STOP: Damage to the vehicle may occur. Do not proceed until process has been complied with.
	OPERATOR SAFETY: Use caution to avoid risk of injury.
	CAUTION: A process that must be carefully observed in order to reduce the risk of damage to the accessory/vehicle and to ensure a quality installation.
	TOOLS & EQUIPMENT: Used in Figures calls out the specific tools and equipment recommended for this process.
	REVISION MARK: This mark highlights a change in installation with respect to previous issue.
	SAFETY TORQUE: This mark indicates that torque is related to safety.

Procedure

Care must be taken when installing this accessory to ensure damage does not occur to the vehicle. The installation of this accessory should follow approved guidelines to ensure a quality installation.

These guidelines can be found in the "Accessory Installation Practices" document.

This document covers such items as:-

- Vehicle Protection (use of covers and blankets, cleaning chemicals, etc.).
- Safety (eye protection, rechecking torque procedure, etc.).
- Vehicle Disassembly/Reassembly (panel removal, part storage, etc.).
- Electrical Component Disassembly/Reassembly (battery disconnection, connector removal, etc.).

Please see your Toyota dealer for a copy of this document.

1. Prepare for the Install.

- (a) Remove the contents from the box and verify that all parts are present and check for any damage.
- (b) See Fig. 1-1 to identify the brackets and their placement.

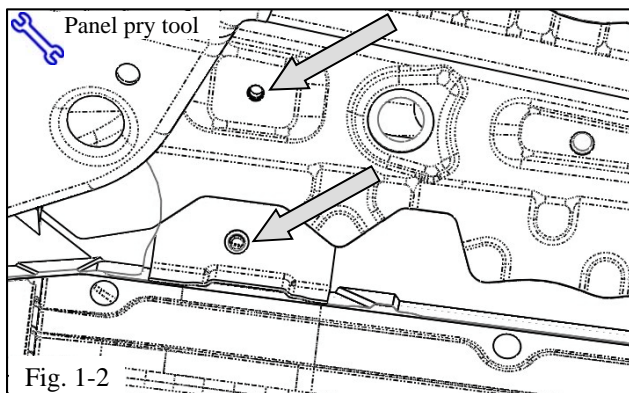
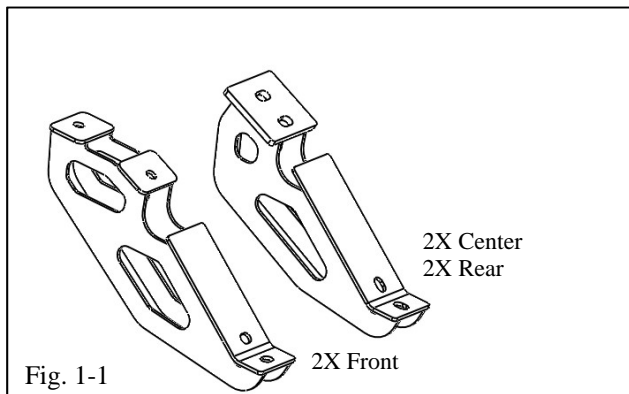

- (c) The front passenger side bracket mounting location is under the floorboard behind the front tire. Remove & discard the plastic screws from the mounting location (Fig. 1-2).

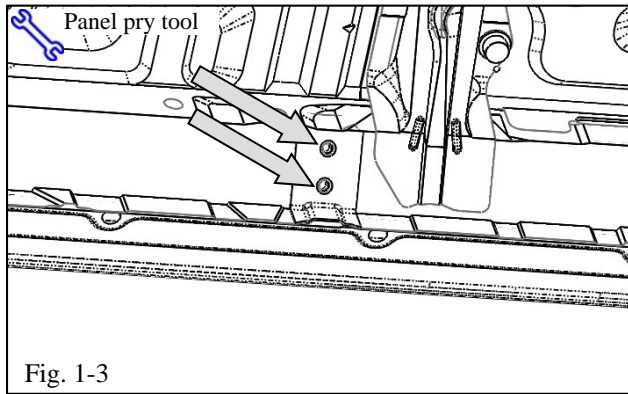

- (d) Remove & discard the plastic screws (4 total) from the middle and rear bracket mounting locations (Fig. 1-3).

2. Install the Passenger Side Tube Step.

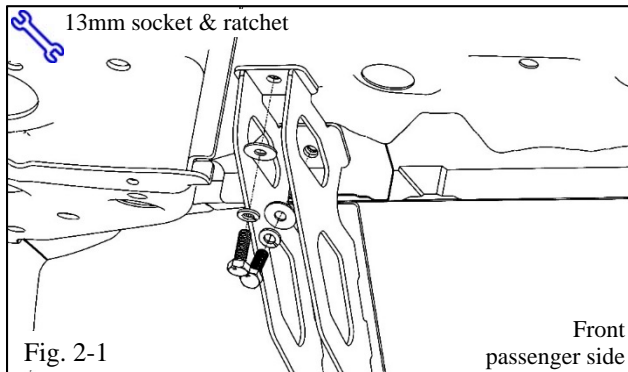

- (a) Use the supplied M8 hex head bolts, flat washers and lock washers to loosely attach the front passenger side mounting bracket to the vehicle (Fig. 2-1).

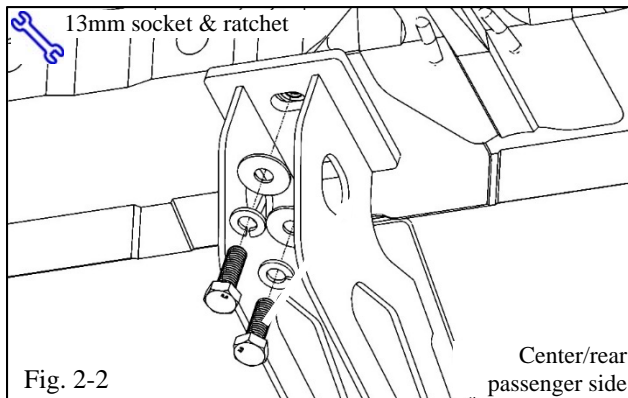

- (b) Use the supplied M8 hex head bolts, flat washers and lock washers to loosely attach the middle and rear passenger side mounting brackets to the vehicle (Fig. 2-2).

⚠ NOTE: The sealant must be removed out of the way of the middle bracket.

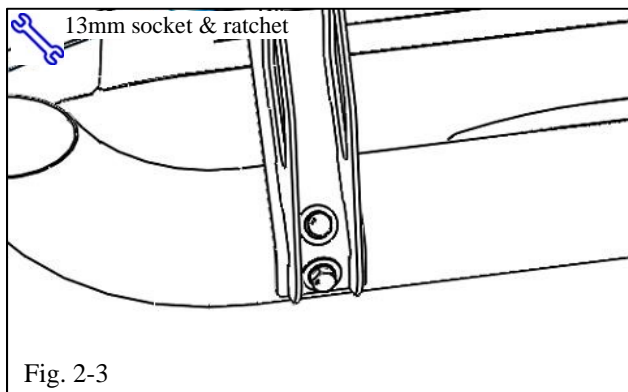



- (c) Use the supplied M8 hex head bolts, flat washers and lock washers to loosely attach the passenger side Step Bar to the mounting brackets (Fig. 2-3).

3. Torque all Hardware.

 (a) Confirm that the brackets are properly seated and perpendicular to the body.

(b) Torque the bolts to the body, outboard first then inboard (front to back).

 **Torque: 23 N-m (17 ft-lbf)**

 (c) Visually align the tube for flatness and torque the bolts to the step bar inboard first then outboard (front to back).

 **Torque: 23 N-m (17 ft-lbf)**

4. Install the Driver Side Tube Step.

(a) Repeat Steps 1 through 3 on the driver side.

5. Re-torque all Hardware.

(a) Re-torque all 24 bolts in the same order as Step 3.

 **Torque: 23 N-m (17 ft-lbf)**

(b) **PPO Only:** Complete the torque audit sheet within five minutes of the installation.

Checklist - these points **MUST** be checked to ensure a quality installation.

<u>Check:</u>	<u>Look For:</u>
<p><u>Accessory Function Checks</u></p> <ul style="list-style-type: none"><input type="checkbox"/> Tube Step alignment<input type="checkbox"/> Inspect bolt torques<input type="checkbox"/><input type="checkbox"/>	<p>Ensure the tube step is centered on the vehicle</p> <p>Complete the torque audit sheet within 5 minutes of the installation (PPO only)</p>
<p><u>Vehicle Function Checks</u></p> <ul style="list-style-type: none"><input type="checkbox"/><input type="checkbox"/><input type="checkbox"/>	
<p><u>Vehicle Appearance Check</u></p> <ul style="list-style-type: none"><input type="checkbox"/> After accessory installation and removal of protective cover(s), perform a visual inspection.	<p>Ensure no damage (including scuffs and scratches) was caused during the installation process.</p> <p>(For PPO installations, refer to TMS Accessory Quality Shipping Standard.)</p>